

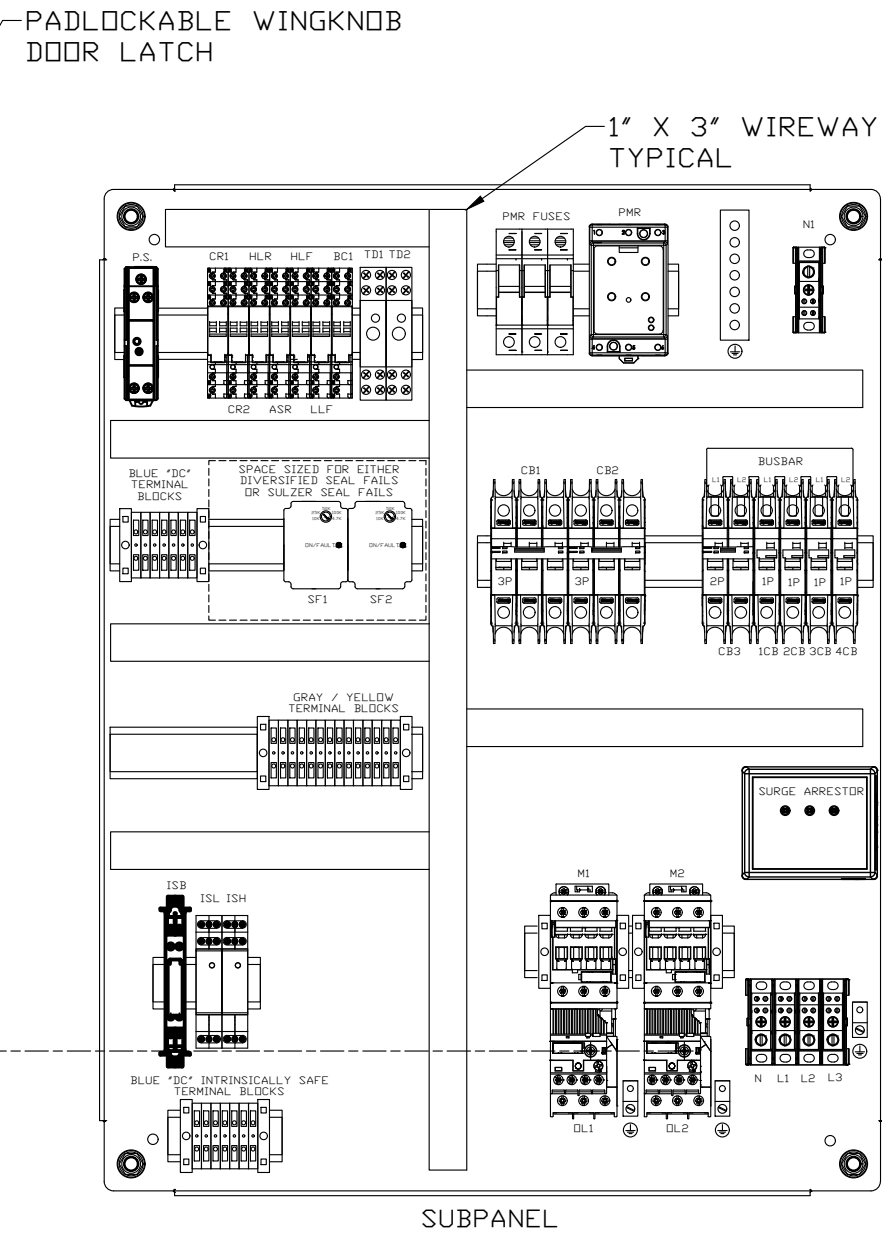

NEMA 1 PAINTED STEEL  
ENCLOSURE  
30"H X 24"W X 10"DP

NAMEPLATE LEGEND

1. PUMP 1 RUN
2. PUMP 2 RUN
3. PUMP 1
4. PUMP 2
5. HAND OFF AUTO
6. SEAL 1 FAIL
7. SEAL 2 FAIL
8. ALARM
9. SILENCE
10. HEATER / BLOWER
11. CONVENIENCE
12. BLOWER

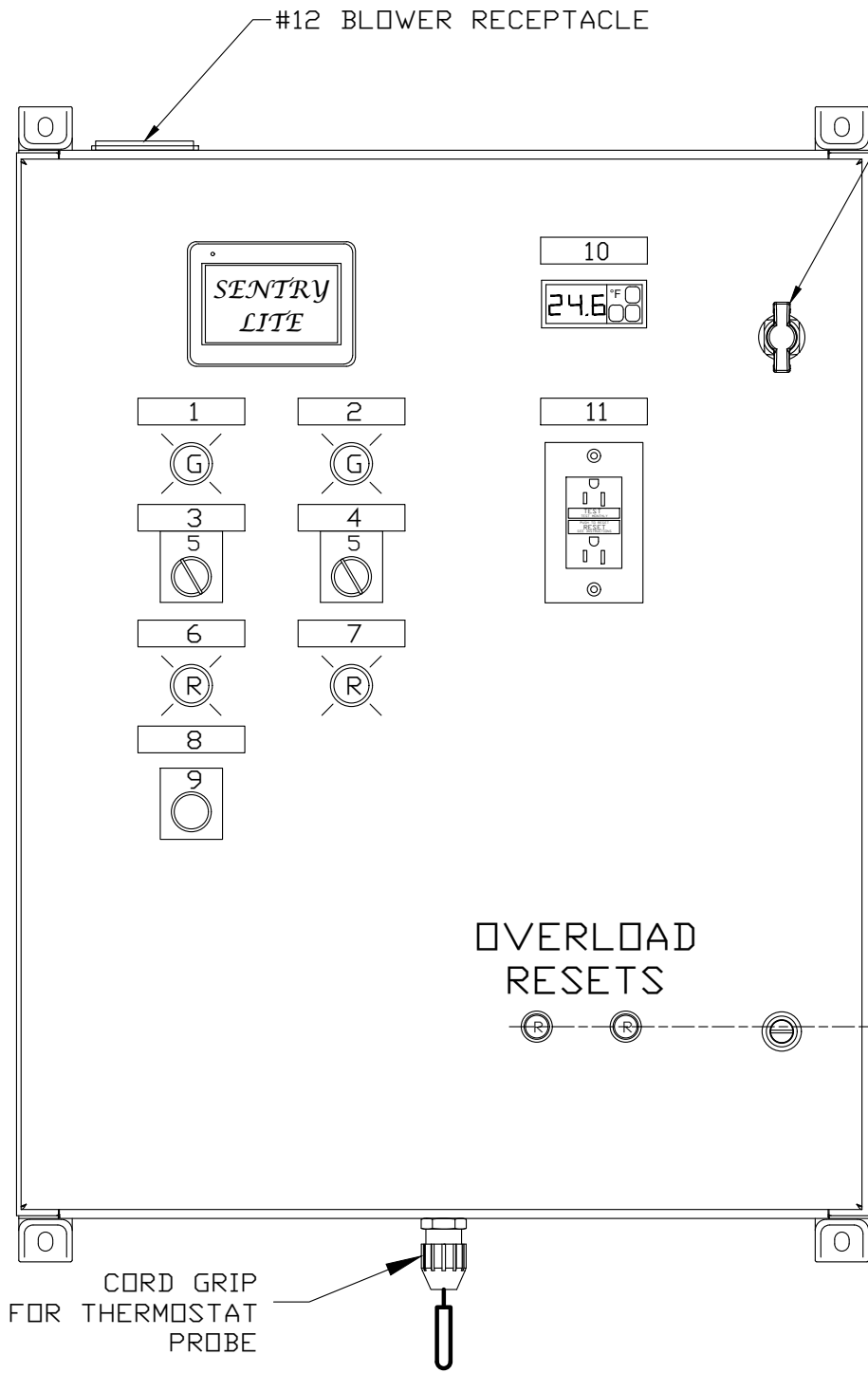

NOTES:

1. USE END STOPS ON EACH SIDE OF THE MOTOR STARTERS TO PREVENT THEM FROM MOVING.
2. PLUG UNUSED CONDUIT HOLES.

CAD3\ELECTRICAL CIRCUIT WBLOCKS\EEE\TOPVAULT\LAYOUTS UTV900800-208-240 PL1.DWG

| REV. NO. | REVISION | BY    | DATE | DESIGNED BY: | DATE | <br>USEMCO INCORPORATED<br>P.O. BOX 550 (608) 372-5911 TOMAH WI. 54660<br>DESCRIPTION<br>DUPLEX 3-PHASE<br>TOPVAULT CONTROL PANEL<br>DWG. NO. UTV900800-208-240 PL1 |
|----------|----------|-------|------|--------------|------|--|
|          |          | CHK'D |      | MH           | 2/19 |  |
|          |          |       |      | MH           | 18   |  |
|          |          |       |      | CHECKED BY:  | DATE |  |
|          |          |       |      | SCALE        |      |  |